

FOR SUBDUED INSIGNIA

ACU:
YELLOW, GRAY AND BLUE AREAS TO BE BLACK 67138. WHITE AREA TO BE FOLIAGE GREEN 67202. BUFF AREAS TO BE BROWN 67136.

ACU-OCP:
Yellow, Gray and Blue areas to be Black 67138. White areas to be Bagby Green 67204. Buff areas to be Olive Drab 67133.

REVISIONS

LTR	DESCRIPTION	DATE	APPROVED
B	STITCH COUNT ADDED.	08 JAN 2010	pm SAO TLC <i>Charles V. Mugno</i> CHARLES V. MUGNO DIRECTOR

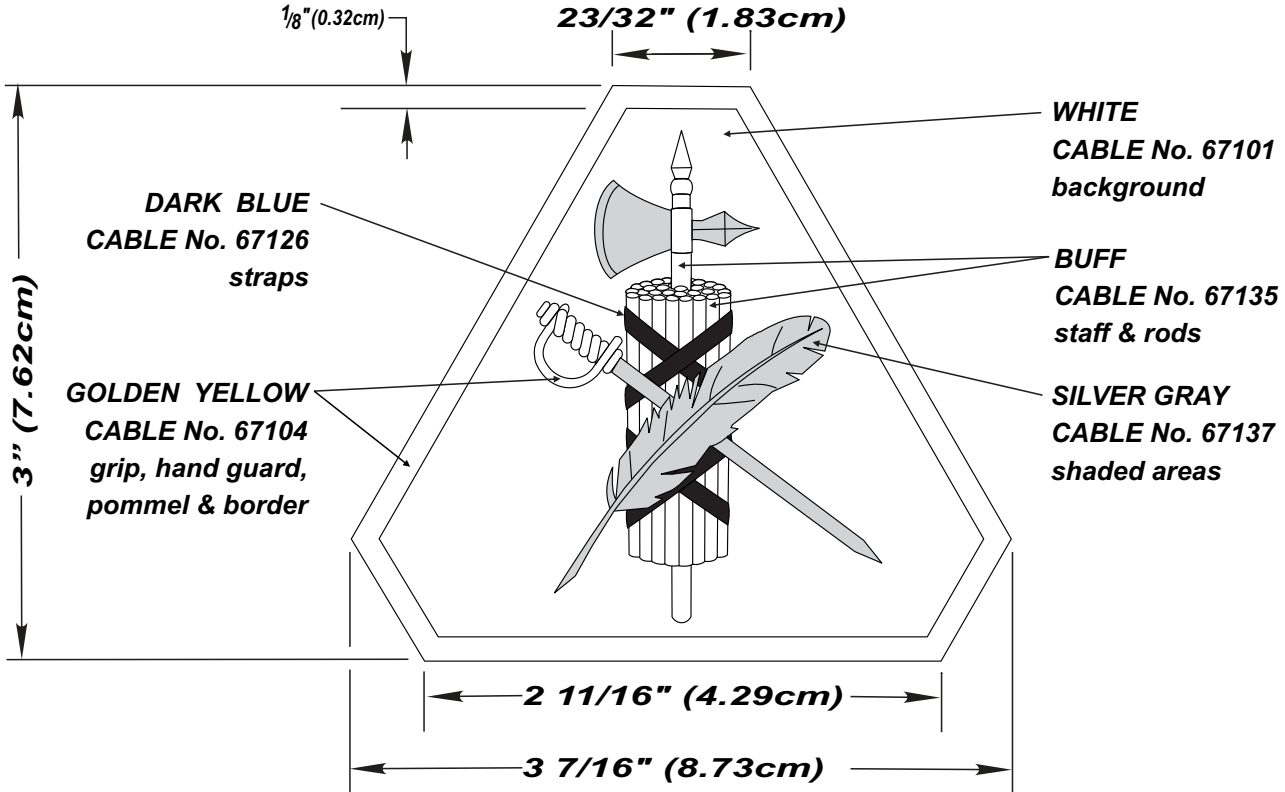

DESIGNED FOR OVEREDGE STITCHING

STITCH COUNT

8115 STITCHES (minimum)

90/2 DENIER

12/4 SPAN

UNLESS OTHERWISE SPECIFIED DIMENSIONS ARE IN INCHES TOLERANCES ON FRACTIONS DECIMALS ANGLES

MATERIALS:
 TO BE MANUFACTURED IN ACCORDANCE WITH MIL-DTL-14652

EXAMINED	pm	
CHECKED	pm	SAO
PREPARED	DMA	
APPROVED	<i>Charles V. Mugno</i> CHARLES V. MUGNO DIRECTOR	

THE INSTITUTE OF HERALDRY, DEPARTMENT OF THE ARMY
 9325 GUNSTON RD, RM S-113 FORT BELVOIR, VA 22060-5579

SHOULDER SLEEVE INSIGNIA
UNITED STATES ARMY RESERVE
LEGAL COMMAND

SIZE	CONTROL IDENT. NO	A - 1 - 1010
A	22571	

SCALE FULL DATE **22 JULY 2009**